

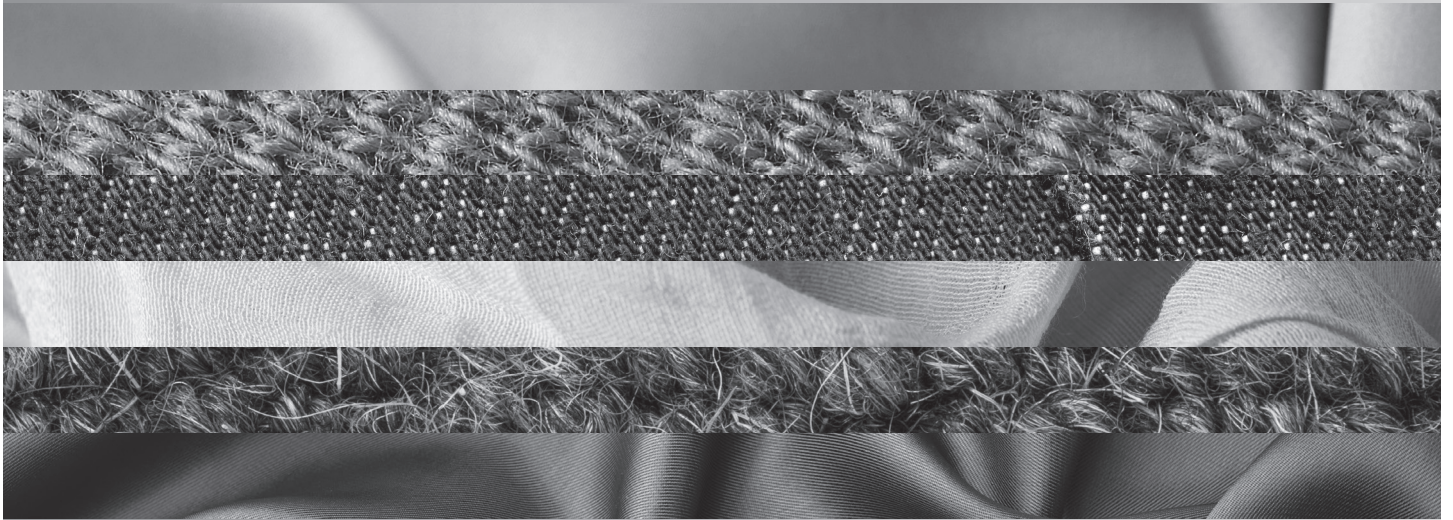

Bienvenidos a la  
lavandería industrial

Welcome to the  
industrial laundry



## User and Maintenance Manual

**C-140/32**

**C-160/32**

**C-200/32**

These technical documents contain confidential information. Please note that unauthorized copying or disclosure of these documents is prohibited and action will be taken against authors of said copies.

**Disposal of Old Electrical and Electronic Equipment**

This symbol on a product or its packaging indicates that this product shall not be treated as household waste. Please dispose of old electrical and electronic equipment at designated collection points for the recycling of such equipment.

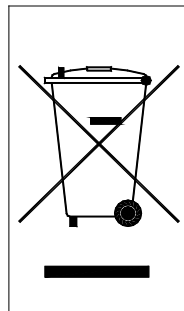

**TECHNICAL INSTRUCTIONS**  
**FLATWORK DRYER IRONER**

# CONTENTS

## 1- GENERAL OVERVIEW

1.1 <u>Introduction</u> .....	5
1.2 <u>Working principle</u> .....	6
1.3 <u>Safety</u> .....	6
1.3.1 User activated safety device.....	6
1.3.2 Heating system safety.....	6
1.3.3 Gas heating system safety.....	6
1.4 <u>Heating</u> .....	7

## 2- INSTALLATION INSTRUCTIONS

2.1 <u>Table of gas specifications</u> .....	8
2.2 <u>Installation</u> .....	9
2.2.1 Handling and unpacking .....	9
2.2.2 Installation room requirements.....	10
2.2.3 Electric connections.....	10
2.2.4 Gas connections (Gas heating only).....	11
2.2.5 Steam and exhaust fume connections.....	11
2.2.6 First start-up.....	11
2.2.7 Conversion to other gas types.....	12

## 3- USER INSTRUCTIONS

3.1 <u>Daily use</u> .....	14
3.2 <u>Breakdown or faulty operation procedure</u> .....	14
3.3 <u>In the event of out-of-service periods (more than 1 week)</u> .....	15

## 4- DESCRIPTION OF MICROPROCESSOR “EASY CONTROL”

4.1 <u>General</u> .....	16
4.2 <u>User interface</u> .....	16
4.3 <u>Machine use</u> .....	17
4.3.1 Start-up.....	17
4.3.2 Shutdown procedure.....	17
4.4 <u>Control of roller rotation</u> .....	18
4.5 <u>Heating</u> .....	18
4.5.1 Electric resistor heating.....	18
4.5.2 Gas heating.....	19
4.5.3 Programming the working temperature.....	20
4.6 <u>Alarm messages</u> .....	21

4.6.1 Insufficient airflow (AL1) – Gas heating only.....21  
4.6.2 Fan thermal relay (AL4).....21  
4.6.3 Speed regulator alarm  
(AL5).....21  
4.6.4 No flame (AL6) – Gas heating only.....22  
4.6.5 Overheating or faulty temperature sensor (or disconnected) (AL7).....22

**5- PERIODIC SERVICING**

5.1 Daily before start-up (machine stopped and cold).....23  
5.2 Every week (before start-up).....23  
5.3 Every 3 months.....23  
5.4 Every 6 months.....24

**6- MAINTENANCE INSTRUCTIONS**

6.1 Replacement of introduction strips.....25  
6.2 Replacement of ironing strips.....25  
6.3 Replacement of support rollers.....26  
6.4 Replacement of side rollers.....26

**7- APPENDICES**

## 1. GENERAL OVERVIEW

### 1.1. Introduction

Thank you for the confidence you have placed in our product. We hope it meets your needs.

The guarantee does not cover damage to glass components, or consumables (seals, bulbs, etc.) nor damage to insulation material or damage due to the incorrect installation of the appliance, or to inappropriate use, inadequate maintenance or poor repair processes.

This appliance is subject to change and modifications for its technical progress.

**WARNING:** To reduce the risk of electrical shocks or injury when using the appliance, basic precautions should be taken, including the following:

- 1- **READ** all the instructions prior to using the appliance and **KEEP THEM** in an easily accessible place for reference in the event of doubt.
- 2- This appliance must be installed by an Official or authorised Technical Assistance Service. Incorrect installation, adjustment, service or inadequate maintenance, as well as incorrect handling of the appliance may cause material damage and injury. Before commissioning the appliance, carefully read the instructions contained in this manual. These contain important information about the installation of the appliance.
- 3- The incorrect installation, inappropriate servicing, poor maintenance and/or cleaning and modifications to the appliance may cause damage to the appliance and injuries to users.
- 4- Failure to comply with the given procedures will result in the loss of cover under guarantee.
- 5- Switch off the appliance in the event of breakdown or faulty operation.
- 6- **DO NOT DRY/IRON** clothes which have been previously treated, washed, soaked or stained with petrol, dry cleaning solvents, or other flammable or explosive substances, as these give off vapours which may catch fire or explode.
- 7- **DO NOT ADD** petrol, dry cleaning solvents or other flammable substances to the washing water. These substances give off vapours, which may catch fire or explode.
- 8- **DO NOT ALLOW** children to play in or on the appliance. Children should be under strict supervision when in the vicinity of a machine which is operating.
- 9- **Do not install or store** the appliance in the open (outside).
- 10- **Do not force** the controls.
- 11- **Do not repair or replace parts** of the appliance or carry out any maintenance unless recommended to do so in the User Instruction Manual. Ensure that you fully understand the instructions and have the necessary skills to carry out the operations described.
- 12- Do not remove any safety devices or modify any components of the washing machine. **DO NOT INSTALL** foreign objects inside the machine.
- 13- Failure to comply with any of the instructions given in the User Instruction Manual may result in personal injury. It is not possible to provide warnings about risk and hazards for all possible situations and contingencies. Therefore, any person involved in the transportation, installation, use or maintenance of the machine should always employ **common sense**, caution and care.

- 14- **DO NOT** use the machine unless all the covers and guards are correctly fitted and secured.
- 15- The distributor (vendor) **MUST** correctly instruct the user during machine commissioning.
- 16- Clean the introduction and collection trays daily.

## 1.2. Working principle

The laundry is to be laid flat on the introduction tray located at the machine front, then the Laundry is automatically dragged towards the drying-ironing roller by the nomex-polyester introduction strips.

Then the laundry passes under the pressing roll wrapped in cloth; automatically adjusted constant pressure, which is controlled by the compensating springs, irons the laundry according to its thickness.

The drying and ironing is then carried out using “Nomex” quality strips and a heating roller.

Strip tension may be adjusted using the flexible spring mounted on a tension rack.

When the laundry is dried and ironed, it is directed towards the collection tray by teflon metal spring slats (low-friction and spring resistance to +250°C).

The laundry is thus delivered dry and perfectly ironed for an impeccable appearance and presentation.

## 1.3. Safety

### 1.3.1 User activated safety device

User safety is guaranteed by a plate located just behind the introduction tray that protects the user from inserting their hands too far into the appliance.

The slightest contact with this safety plate causes the machine to stop immediately. This plate is the machine’s main emergency-stop device (available over the full roller length).

A second emergency device is located near the control panel.

### 1.3.2 Heating system safety

The temperature sensor connected to the control panel and placed inside a plated probe on the heating roller, ensures that the temperature of the ironing roller remains below the overheating limits of the strips (the heating is switched off when the temperature reaches a maximum of 180°C).

A safety thermostat (190°C), also placed inside a plated probe on the heating roller, switches off the heating when the temperature sensor fails.

### 1.3.3 Gas heating system safety

When a gas system fault occurs, the gas supply to the machine is shut off and the AL6 alarm appears on the display.

After the beep has ended, reset the gas system by pressing the + and – buttons simultaneously (see alarm chapter). If the fault persists, this could be due to one of the following problems:

- The gas supply may be shut off: check that the gas supply valve is open.
- Faulty ignition spark plug: replace.
- Exhaust tubes are blocked: check draft.

## 1.4 Heating

2 heating modes are available so that the machine may be adapted to the environment:

- Electric heating: provided by 6 shielded components mounted on a box.
- Gas heating: heating ramp running the length of the machine allows uniform heating from one end to another.



Ignition is guaranteed by an electronic ignition device, including one spark plug and flame control. Manual intervention is therefore avoided completely and the system is completely safe. Safety is further increased due to a dual safety electronic valve at the point where the gas piping enters the machine.



## 2. INSTALLATION INSTRUCTIONS

### 2.1. Table of gas specifications

Information relating to the installation of type gas heated dryer-ironers.

<b>Country</b>	<b>Class</b>	<b>Gas</b>	<b>Pressure (mbar)</b>					
Germany (DE)	I2ELL	G20	20					
		G25	20					
	I3P	G31	50					
Austria (AT) Denmark (DK) Finland (FI) Italy (IT) Sweden (SE) Czech Republic (CZ) Norway (NO)	I2H	G20	20					
SWITZERLAND (CH) Spain (ES) Ireland (IE) Portugal (PT) United Kingdom (GB) Greece (GR) Estonia (EE) Lithuania (LT) Latvia (LV) Slovakia (SK) Slovenia (SL) Romania (RO) Bulgaria (BG)	II2H3P	G20	20					
		G31	37					
	SWITZERLAND (CH) Spain (ES)	II2H3P	G20	20				
			G31	50				
	Belgium (BE)	I2E+	G20/G25	20/25				
	Belgium (BE) Cyprus (CY) Malta (MT)	I3P	G31	37				
					France (FR)	II2Esi3P	G20/G25	20/25
							G31	37 and 50
	Luxemburg (LU)	II2E3P	G20	20				
			G31	50				
	THE NETHERLANDS (NL)	II2L3P	G25	25				
			G31	50				

The nameplate for this appliance is located on the left side panel and contains the following information:

- The type of machine
- Serial number
- Power supply
- Fuse rating
- GAS specifications

## 2.2. Installation



**Caution:** this machine may only be installed, adjusted, updated and started up by accredited technicians or resellers.

Likewise, it is strongly recommended that the client be present during installation and first testing.

The appliance must be installed in accordance with current norms and regulations, in a room with sufficient ventilation.

The flow of fresh air required, in square metres per hour, to supply the oxygen needed for combustion is as follows:

MODEL	C-140/32	C-160/32	C-200/32
AIR FLOW (m3/h)	28	45	60

### 2.2.1 Handling and unpacking

Upon delivery, the machine must be in perfect condition and the packing material must not be incomplete or damaged. Pay attention to the markings on the packaging (e.g. FRAGILE, UP/DOWN, PROTECT FROM RAIN, etc). The machine is quite heavy and has imposing dimensions (see below). Provide for adequate lifting and handling devices in order to proceed safely.

The machine must be handled using a lift-truck of sufficient capacity and the truck forks must be opened as much as possible to avoid turning the machine over.

The machine must be lifted at its centre (centre of gravity on the axis).

Do not drop or turn the machine over, e.g. when unloading.

**Note:** lifting with slings is not advised; such handling is performed under full responsibility of the person handling the machine (as there is a risk of deforming the machine).

MODEL	C-140/32	C-160/32	C-200/32
Width (without and with packaging) in mm	1960 / 2340	2210 / 2340	2780 / 2740
Depth (without and with packaging) in mm	644 / 770	644 / 770	644 / 770
Height (without and with packaging) in mm	1107 / 1400	1107 / 1400	1107 / 1400
Weight (without and with packaging) in kg	300 / 335	355 / 375	428 / 435
Volume (without and with packaging) in m3	1.40 / 2.52	1.58 / 2.52	1.83 / 3.00

### 2.2.2 Installation room requirements

The machine must be installed in a well-ventilated room (particularly when using gas heating) with correct lighting and an ambient temperature not exceeding +10°C to +40°C (temperature limits for the electronic frequency regulator of the driving motor). Below +10°C, the temperature sensor will not work and the control panel will display an alarm (AL7).

Sufficient space must be provided around the machine to allow for correct operation:

- **5 to 10cm** minimum at the back to allow for ventilation.
- **60 to 80cm** on each side to allow for servicing and maintenance.
- Sufficient space must be provided at the front of the machine to allow the operator to work correctly and safely.

Levelling should be carried out on a hard and stable floor that can support the significant weight of the machine (400 to 500kg on 1.6 to 2m<sup>2</sup>).

The installation of this appliance requires a floor that can support a minimum of **500kg per m<sup>2</sup>**.

### 2.2.3 Electric connections

The electric cable is not included.

The machine must be connected to electric using an electric cable according to the specifications in the table below. It must also be protected by a **differential circuit breaker (not included)**.

The electric installation must comply with current regulations.

ELECTRIC HEATING - E				
MODEL		C-140/32	C-160/32	C-200/32
MOTOR POWER (KW)		0.37	0.37	0.49
ELECTRIC POWER (ELEC. HEATING) (KW)		12	16	21
POWER SUPPLY (ELEC. HEATING) (KW)		12.37	16.37	21.49
FUSE RATING (ELEC. HEATING)(A)	400V + T + N	20	25	32
	230V + T	32	50	63
CABLE SECTION (ELEC. HEATING) (mm <sup>2</sup> )	400V + T + N	5 x 4	5 x 4	5 x 16
	230 V + T	4 x 6	4 x 10	4 x 35

GAS HEATING - G				
MODEL		C-140/32	C-160/32	C-200/32
MOTOR POWER (KW)		0.37	0.37	0.49
ELECTRIC POWER (ELEC. HEATING) (KW)		0.37	0.37	0.49
FUSE RATING (ELEC. HEATING)(A)	400V + T + N	2	2	2
	230V + T	2	2	2
	400V + T + N	5 X 2.5	5 X 2.5	5 X 2.5

CABLE SECTION (ELEC. HEATING) (mm <sup>2</sup> )	230 V + T	4 X 2.5	4 X 2.5	4 X 2.5
--	-----------	---------	---------	---------

### **2.2.4 Gas connections (Gas heating model only)**

For machines using this type of heating, connect the appliance to the existing gas pipe and insert a blocking valve to isolate the appliance from the rest of the installation (DTU 61.1 for France).

The installation must comply with current norms and regulations of the relevant country.

The gas supply piping must be of sufficient dimension to minimise pressure loss: its diameter must be determined by the direction of the piping (length, number of bends, etc) and the power of the appliance.

Please refer to the table below (paragraph 2.2.6) for the different gas specifications.

**Check that the appliance settings correspond to the type and pressure of gas available at the installation site.**

**To check the pressure of the gas supply to the appliance, connect a pressure gauge to the connection located on the electronic valve module while the heater is on.**

**The gas pressure reading must be the same as the pressure indicated on the appliance label for the gas type used.**

**A pressure regulator (not included) corresponding to the type and pressure of the gas used (see technical specifications) must be installed on the piping close to the machine.**

### **2.2.5 Steam and exhaust fume connections**

The exhaust piping is not included.

Steam extraction (and of the gas burnt by machines using gas heating) is carried out using 1 (C-140/32 and C-160/32) or 2 (C-200/32) fan motors: dynamically balanced (airflow: **500m<sup>3</sup>/h** each and a pressure loss of **60Pa** when extracted by the fan).

The connection of the exhaust piping **MUST** be directed outwards.

The exhaust piping, with a diameter of 98mm when leaving the machine, must be connected by the shortest route possible to 2 chimneys of 100mm minimum diameter or otherwise to 1 chimney of at least 200mm (connected in “Y” and not in “T”).

The distance between the piping must not exceed 5 metres and 1 bend. Beyond these dimensions it may be necessary to increase the diameter of the piping and/or to add another fan motor to the extraction piping (to be sized according to the technical specifications of the fan motor, as mentioned above). The possible addition of an extra extraction motor in the piping is not sized.

The chimney used to evacuate the steam and smoke from the dryer-ironer should not be used for the evacuation of any other appliance.

### **2.2.6 First start-up**

- When starting for the first time, ensure that the machine is stable and level.
- Check that all connections and exhaust piping is made correctly.
- Check the machine is connected to earth correctly.

- Check that the temperature sensor is in its normal position (curved face in contact with the roller)
- Turn the lockable switch to position 1.
- Press the START button.
- Check that the fan motor rotates and rotates in the correct direction (see arrow on the motor). The fan motors are located on the left and right sides of the machine casing (specifically on the right side for models C-140/32 and C-160/32)
- Check that the introduction strips rotate and that they rotate in the correct direction (towards the inside of the machine).

**Caution:** do not touch or get too close to moving parts in the machine.

- Replace all machine casing.
- Check that the temperature increases.
- Adjust the temperature settings according to the laundry to be ironed.
- Proceed to test the ironing, the laundry must be dry and perfectly ironed.

If this is not the case, increase the temperature or reduce the ironing speed.

**Caution:** the roller is coated in wax when it leaves the factory. It is therefore recommended to carry out the first tests on worn laundry.

### **2.2.7 Conversion to other gas types.**

This operation requires the injector to be changed and the air ring to be adjusted.

- Remove all screws keeping the right and left sides of the electrical cabinet in position and turn the cabinet to access the inside of the right side.
- Using a wrench, remove the main injector and replace it with an injector that is appropriate for the type of gas to be used.
- Adjust the air ring according to the type of gas.

#### **A I R A D J U S T M E N T**

Diagram of air adjustment by means of distance "d"

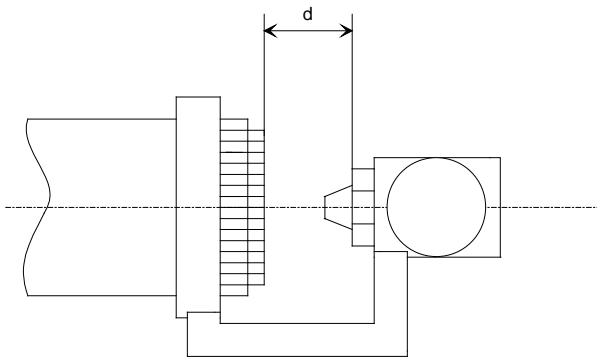

**Table of adjustments and flow rates**

**NATURAL GAS**

Gas type	G20			G25			G25		
Gas supply pressure (mbar)	20			20			25		
Model	C-140/32	C-160/32	C-200/32	C-140/32	C-160/32	C-200/32	C-140/32	C-160/32	C-200/32
Size of injector	2.8	3.5	4	3.1	3.9	4.5	2.9	3.6	4.2
Air adjustment "d" (mm)	4	4	4	0	0	0	0	0	0
Gas flow (m3/h)	1.5	2.4	3.2	1.7	2.8	3.7	1.7	2.8	3.7
Heat flow (KW)	14	22.5	30	14	22.5	30	14	22.5	30

**PROPANE GAS**

Gas type	G31			G31		
Gas supply pressure (mbar)	37			50		
Model	C-140/32	C-160/32	C-200/32	C-140/32	C-160/32	C-200/32
Size of injector	1.9	2.4	2.7	1.75	2.3	2.5
Air adjustment "d" (mm)	18	18	18	18	18	18
Gas flow (m3/h)	1.1	1.7	2.3	1.1	1.7	2.3
Heat flow (KW)	14	22.5	30	14	22.5	30

G20: natural gas type H (Lacq)

G25: natural gas type L (Groningue)

G31: propane gas

## 3. USER INSTRUCTIONS

### 3.1. Daily use

Please refer to chapter 4 for instructions on using the control panel

- Turn the lockable switch to position 1.
- Press the START button.
- Check that the strips rotate.
- Choose an ironing speed between 1 and 7 (0 to use the “SMART SYSTEM” option).
- Adjust the temperature settings according to the moisture level and type of laundry to be ironed.



**Important:** the working temperature varies according to the textiles to be ironed but must never exceed 180°C during continuous operation.

A preset safety thermostat (of 190°C) is located inside the machine. Its primary function is to prevent any possible failure of the control system.

- When starting, it is essential to wait for the machine roller to reach a temperature close to the temperature required (the heating light will remain on until the temperature has been reached).
- When ironing small pieces of laundry, it is essential to work consecutively using the whole length of the ironer, this will help to achieve constant results and a better lifespan for the ironing strips, which would otherwise suffer from rapid deterioration.
- In order to achieve perfectly dried and ironed laundry, the working speed must be adjusted according to the nature and moisture level of the laundry to be ironed. The laundry moisture level when inserted into the machine must be between 40 and 50% maximum.

**Important:** when finished, press the STOP button. The machine will automatically stop when the roller naturally cools down to the programmed stop temperature (80°C by default).

**Extremely important:** never stop the machine if the temperature is equal to or higher than 80°C (there is a risk of damaging the strips).

Finally, isolate the ironing strips from the roller by introducing a thick, dry cloth (or a dry sheet folded in half) feeding it both over the top and underneath.

Never leave moist laundry in the machine as this can cause the roller to corrode.

### 3.2 Breakdown or faulty operation procedure



**Power failure: caution** when the power fails (the machine stops while the roller is hot) is it essential to **immediately** isolate the ironing strips from the roller.

To do this, feed a thick and very wet cloth (hardly wrung dry) into the machine while rotating it using the crank handle provided (the crank handle must be accessible at all times, its primary position is on the right hand side panel of the machine).

Having removed the wing nut to flip the red safety plate, insert the crank handle into the opening on the right side panel of the machine.

If necessary, feed a very wet piece of laundry into the machine several times in order to cool the roller down as quickly as possible.

At least two people are required to perform this operation **in case of an emergency**; one or two to feed the laundry while one turns the crank handle.

Replace the wing nut on the right side panel of the machine after handling, as it creates a contact which enables the control panel to switch on.

### **Other faults**

- If the machine does not start (the roller does not rotate) or if the machine suddenly stops, check that the emergency stop devices have been triggered (emergency stop button, finger-safety plate or wing nut on the right side panel). After deactivating the emergency stop devices, restart the machine by pressing the START button.
- If the safety plate (red plate covering the introduction strips) is triggered while the machine is operating, the machine will stop. Start the machine back up again immediately by pressing the START button (to avoid damaging the strips).
- If other faults or unusual noises occur (rubbing, banging, etc) stop working and contact the authorised dealer immediately, describing the problem in detail.

### **3.3 In the event of out-of-service periods (more than 1 week)**

To prevent roller corrosion, particularly in the case of out-of-service periods (more than 1 week), it is important to coat the roller with a layer of paraffin. Proceed as follows:

- Machine off, roller slightly warm (between 110°C and 100°C during the cooling phase)
- Remove the control panel.
- Set the roller to rotate slowly.
- Coat the surface of the roller with the paraffin in successive layers to coat the entire surface of the roller.
- Insert a dry piece of laundry around the roller.



## 4. DESCRIPTION OF MICROPROCESSOR “EASY CONTROL”

### 4.1 General

A single processor card can be used to control models that differ in terms of roller diameter or heating method (electric, gas or steam).

### 4.2 User interface

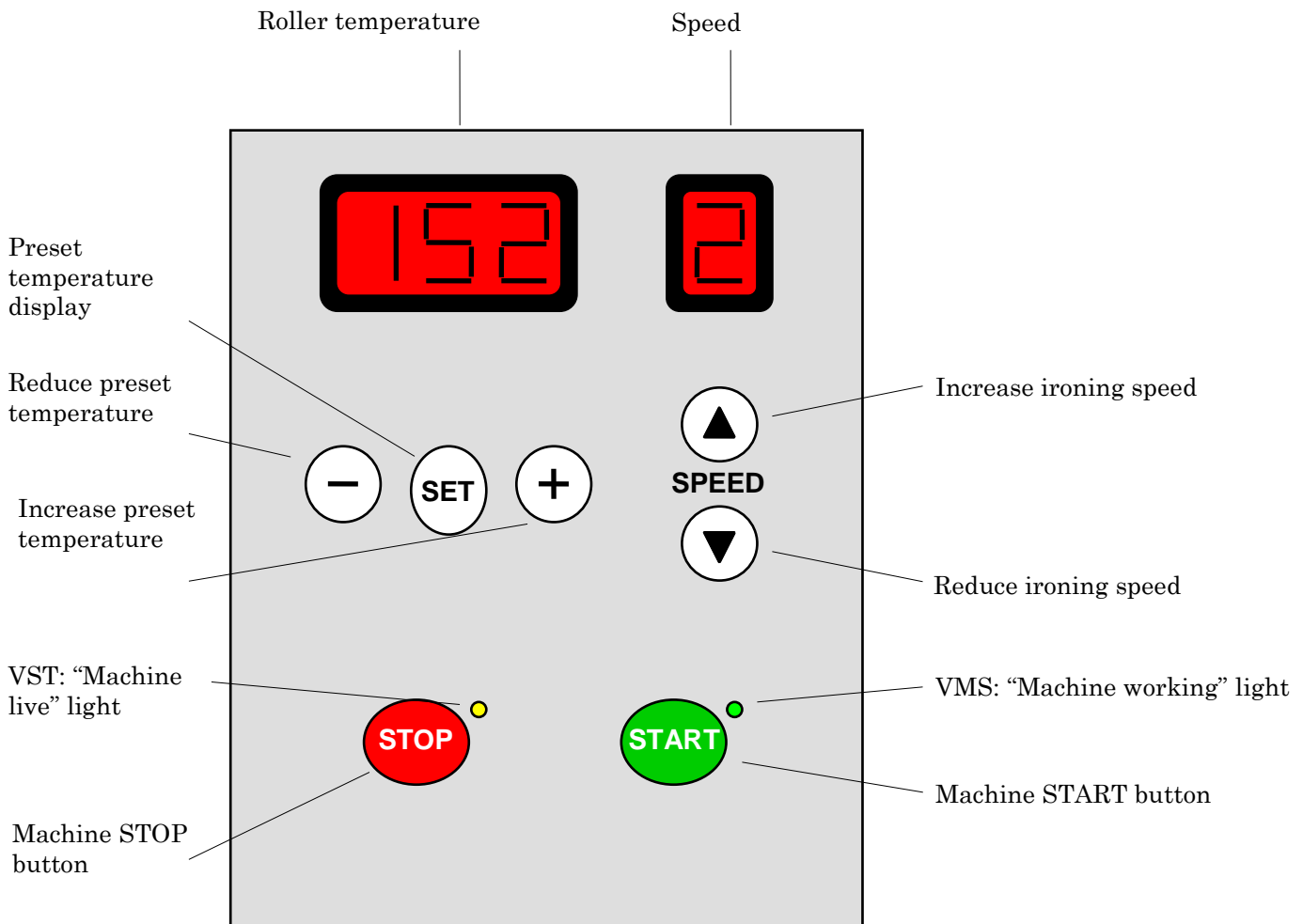

## 4.3 Machine use

### 4.3.1 Start-up

To start the machine, press the START button:



- the display will light up and show the current temperature and preset speed (see chapter on "Control of roller rotation")
- the VMS light will light up (VST is always lit when machine is switched on)
- the fan will start working
- the roller will start rotating
- after 15 seconds, the heating is enabled

### 4.3.2 Shutdown procedure

To stop the machine, press the STOP button.



The shutdown procedure depends on the temperature detected.

- if the temperature is  $\leq$  automatic shutdown temperature TA (80°C by default), the machine will switch off.
- if the temperature is  $>$  temperature TA, only the heating is switched off. When the temperature reaches below temperature TA, the machine will stop completely. During this time, the temperature display and VMS light will flash.

The TA value can be programmed by the manufacturer or during installation (see "Parameter programming").

## 4.4 Control of roller rotation

The roller motor is controlled by a speed regulator.

7 different factory preset speeds can be selected; speed **0** is used for the SMART SYSTEM option.

- The speed can be adjusted when the machine is ON by pressing the “up” and “down” keys. The speed appears on the display.

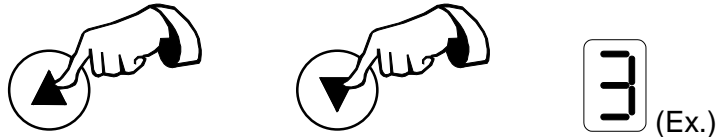

In the case of a power failure, the last selected value will be recalled.

When starting the machine, if the set speed is not 0, the roller will rotate at speed 1 while the detected temperature remains below the operating temperature TF (130°C by default); once this temperature is reached, the preset speed will be activated.

If the temperature drops below TF during operation, the speed will be adjusted.

When the selected speed is 0, the roller will rotate at speed 0 (speed set by the SMART SYSTEM), regardless of the temperature.

## 4.5 Heating

### 4.5.1 Electric resistor heating

Depending on the model of machine, the electric resistor heating operates by modifying the current of one or two groups of resistors, controlled by the heating relay switches.

The choice of 1 or 2 resistors is made by setting a parameter (see "Parameter programming").

#### **Heating by a single group of resistors**

If the machine is configured to work with a single group of resistors, a special control method is activated (closing and opening of the heating relay switch around the set point) to reach and correctly maintain the selected temperature and to avoid thermal inertia due to this type of heating.

It is therefore normal to hear the heating relay switch engaging frequently when this method is selected.

To show that the heating is activated, the decimal point on the temperature display lights up.

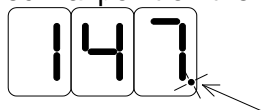

## Heating by two resistor groups

If the machine is configured to work with two resistor groups, modifying the first group of resistors controls the temperature regulation, as if it was the only group to control. Meanwhile the second group of resistors continues operating when the temperature is below the preset temperature, and switches off when the preset temperature is attained. The second group of resistors is activated again when below a preset hysteresis (see "Parameter programming").

To show that the heating is activated when the two heating groups are operating, the decimal point on the temperature display is permanently lit. When a single group is operating, the decimal point flashes.

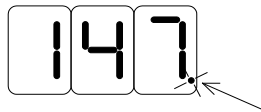

### 4.5.2 Gas heating

If a gas heater produces the heating, the machine is equipped with a special electronic device that controls the ignition and functioning of the heater. The microprocessor controls the gas heater directly when the temperature is lower than the preset temperature.

Reference is made in the alarm section on how to reset the gas device.

To show that the heating is activated, the decimal point on the temperature display lights up.

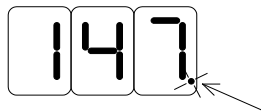

The "Alarm procedures" section explains what to do in the event that there is no flame.

### 4.5.3 Programming the working temperature

The temperature control can be programmed with the machine switched on as follows:

- Press the SET button

The last programmed value will flash on the display

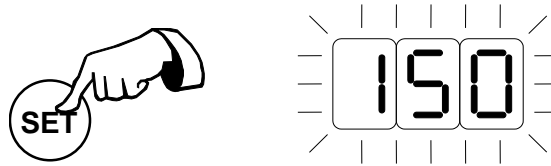

- Use the + and - buttons to modify the value. By holding the key down, the numbers will quickly increase or decrease.



3 seconds after releasing the + or - button, the value is stored and the detected temperature is shown again on the display.

**Programmable range:** 0...Tmax °C (32...Tmax °F)  
**Resolution:** 1°C

The maximum value that the user can set (Tmax) is established by the manufacturer or during installation by a specific procedure. See "Parameter programming".

In group resistor heating, to limit system inertia, a special device allows control around the set point of more or less 5°C.

This device opens and closes the heating relay switch repeatedly when approaching the set point temperature. It is therefore normal to hear the heating relay switch engaging repeatedly, which indicates there are no faults affecting its operation.

## 4.6 Alarm messages

### 4.6.1 Insufficient airflow (AL1) – Gas heating only

The alarm is only controlled when the card is configured to work with gas heating.

If the pressure switch on the chimney opens for 2 seconds, the buzzer is activated for 1 minute and “AL1” appears on the display.

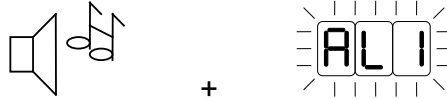

The heating is switched off at this time. Check the direction of the fans (see arrows on the motor) if operating or controlling the exhaust system (if the alarm stops when you disconnect the exhaust pipe at the top of the machine, there is a possibility that the exhaust pipe is too narrow or blocked).

The alarm is not activated within the first 10 seconds of starting the fan, to allow the airflow to settle down.

The alarm is automatically deactivated when the pressure switch returns to its normal position or when the machine is switched off.

### 4.6.2 Fan thermal relay (AL4)

When the fan thermal relay trips, the buzzer is activated for 1 minute and “AL4” appears on the display:

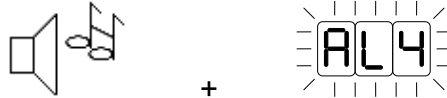

The fan and heating is switched off but the machine remains on.

The alarm is automatically deactivated when all normal conditions are restored (closing the thermal relay contact) or switching the machine off.

This alarm is generally caused when the fan is clogged with dirt.

### 4.6.3 Speed regulator alarm (AL5)

When the speed regulator alarm trips, the buzzer is activated for 1 minute and “AL5” appears on the display:



The machine switches off automatically.

The alarm can be deactivated by restarting the machine or turning it off and on again.

This default may be due to roller motor overload caused by machine jamming or a blockage in the roller motor.

#### **4.6.4 No flame (AL6) – Gas heating only**

The alarm is only controlled when the card is configured to work with gas heating.

When the heater is ignited or is in process of igniting, and if the activated gas device does not generate a flame, the buzzer is activated for 1 minute and “AL6” appears on the display.



The heater ignition control remains active and the machine remains switched on.

To try and re-ignite the burner, press the + and – buttons simultaneously after the alarm stops.



When the gas device cancels the default message, the alarm is also cancelled. If the reset fails, the alarm will activate again. This may be due to one of the following problems:

- No gas supply: check that the manual gas shutoff valve is open
- Insufficient gas pressure or incorrect gas type (see installation chapter)
- Faulty ignition spark plug: replace

To cancel the alarm without igniting the heater, switch off the machine by pressing the STOP button.

#### **4.6.5 Overheating or faulty temperature sensor (or disconnected) (AL7)**

If the temperature sensor is faulty or is not connected, or if it detects a temperature above **210°C** continuously for 2 seconds, the buzzer is activated for 1 minute and “AL7” appears on the display.

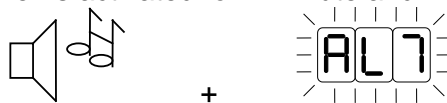

The machine will still operate and the alarm can be cancelled by switching off the machine.

## 5. PERIODIC SERVICING



All servicing must be performed when the machine has stopped, the roller is cold and the circuit breaker is in position 0.

### 5.1 Daily before start-up (machine stopped and cold)

- Check the contact between the thermostat probe and the roller and visually check that there are no foreign objects between the two.

For this purpose, exert pressure onto the thermostat probe by hand.

### 5.2 Every week (before start-up)

- Clean the inside surface of the thermostat probe. For this purpose, rotate the probe by 90° and remove any built up fibres and lint from the probe by hand.

Return the probe to its initial position.

- Remove the top panel (which is fixed with 2 screws, use a male 6 sided wrench of 5mm). Check for the presence of galons between the pressing roller and the braid guides.

If a braid is missing, replace it immediately with a braid of the same type (special high temperature braid).



The galons are to be fitted loosely in position when replaced. Do not stretch them as this could cause them to break prematurely.

### 5.3 Every 3 months

#### Cleaning:

- Check the thermostat probe is clean by rotating it 90° then put back into place and check that it rests on the roller correctly.
- Clean the exhaust pumps as well as the fan housing and exhaust piping (particularly the bends).
- Clean the fan motor and driving motor ventilation grids.
- Clean the roller as soon as a layer (generally white) of scale or detergent residue builds up.
- Clean the slats that remove the laundry from the roller and direct the pieces into the collection tray.

#### Greasing:

- Grease the chains and the drive gears as well as the driving chain of the pressing roller.



### **Adjustments:**

- Check that the introduction strips have the correct tension. They must be lightly stretched and must turn over the driving roller without slipping.

To loosen the strips, undo the screws at both ends of the introduction tray and slide the tray.

- Check the tension of the ironing strips. Particularly during the first few times of operating, the strips have a tendency to lengthen slightly.

In order to tighten the strips again, the two tensors at each end of the machine need to be used. Remove the side panels and then adjust the tensors in such a way that the ironing strips make sufficient contact with the roller to drive it along correctly without slipping, even with the laundry.

**Caution:** apply the same tension to each tensor.

Do not stretch the strips too much as there is a risk of rapid deterioration.

- Check the pressure of the pressing roller. It must not compress the roller too much but just enough to achieve good quality ironing; its role being to flatten the laundry.

**Caution:** apply the same tension to each tension spring.

- Check the tension of the driving chain (right side of the machine), the chain must not “beat” as there is a risk that it may break.

To tighten the chain, move the adjustable gear along its rail.

## **5.4 Every 6 months**

- In the case of gas heating, check the exhaust fume piping and have the chimney swept if necessary. Also carry out thorough cleaning on the gas heating ramp
- In the case of electric heating, check that the exhaust fume pipe is not partially blocked and clean if necessary.

## 6. MAINTENANCE INSTRUCTIONS

Before any intervention, the machine must be stopped, the roller cold and the circuit breaker in position 0.

### 6.1 Replacement of introduction strips

- Remove the 2 screws securing the introduction tray.
- Unlock the axis of the driving roller on the side of the left block (2 pointed screws).
- Unwind approximately half a turn of adhesive strip.
- Push away the pin while maintaining the axis in place (identify the direction in which the axis is mounted).
- Remove the axis by pushing on the left.
- Withdraw the introduction tray.
- Remove the used introduction strips and replace with new strips.
- To reassemble, reverse the instructions above.
- Glue the adhesive strip back on using neoprene glue.
- Check the distance between the end of the introduction tray and the roller. The distance must be a minimum of 5 to 6mm.

**Note:** always change the full set of strips.

### 6.2 Replacement of ironing strips

- Remove the side panels.
- Loosen the tension blocks as much as possible.
- Move the clip of the ironing strip forward to the front roller.
- Connect the old strip to the new strip.

**Mind the position:** the Nomex side (darker), the side with the flap, must be against the roller.

Make the machine turn very slowly.

- Stop at the position of the clip.
- Remove the old strip.
- Clip the 2 ends of the new strip by moving the axis in between the clips.
- Repeat this operation for the other strips.
- Adjust the tension of the strips if necessary.

**Note:** always change the full set of strips.

### **6.3 Replacement of support rollers**

- Remove the top panel.
- Remove the side panels.
- Lift the roller using an appropriate tool (jack, maintenance crane, etc).
- Loosen the blocking screws for the support rollers on the support roller bar (2 pointed screws).
- Remove the bar and the rollers.
- Reassemble the bar with new rollers.
- Fix the rollers into place on the bar (see required distance).
- Fix the bar onto the level blocks.
- Replace the panels.

### **6.4 Replacement of side rollers**

- Remove the side panels.
- Remove the screw securing the roller in place.
- Remove the spacer from the used roller.
- Place the new roller onto the spacer.
- Put the new roller in place.

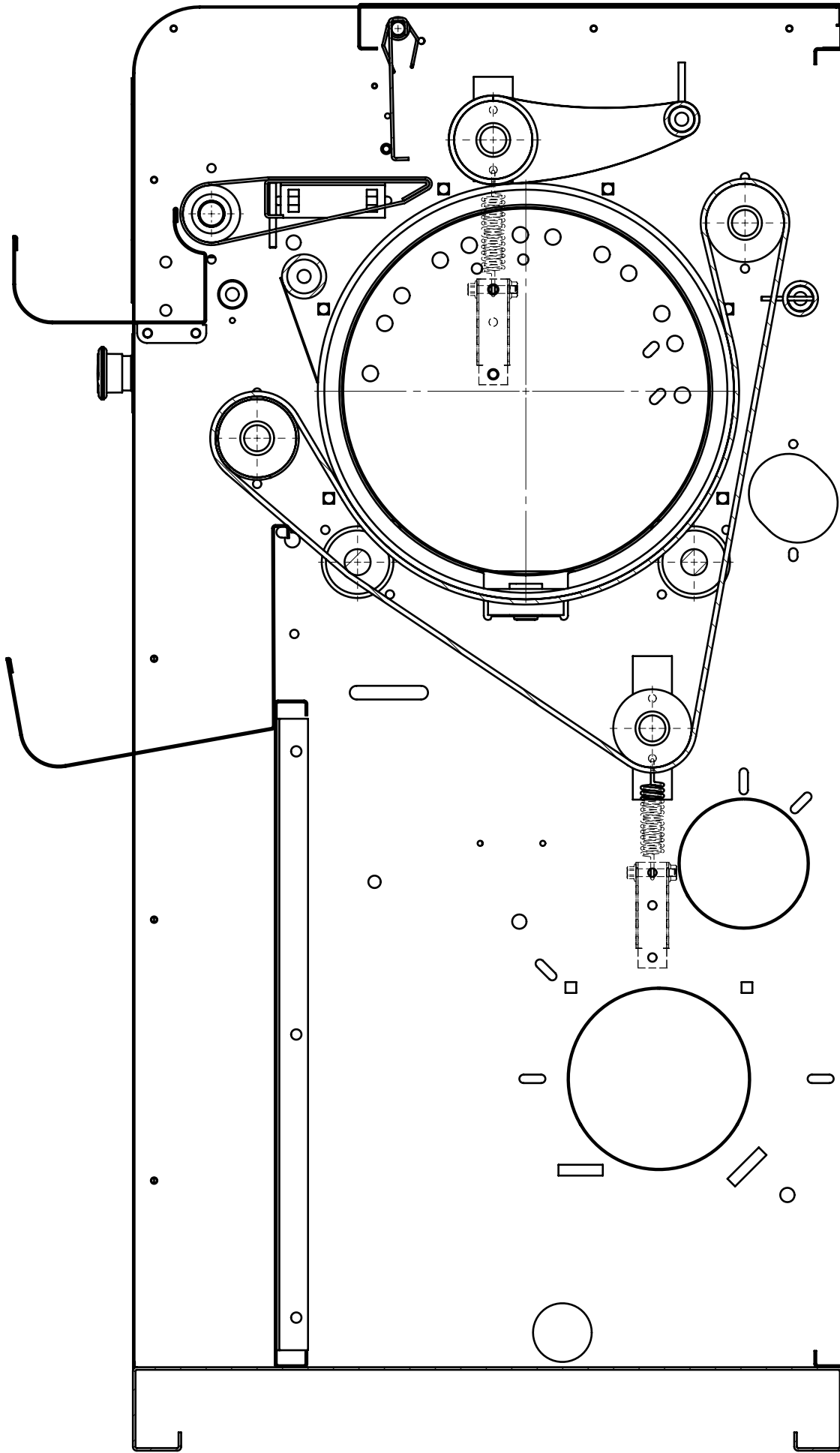

**DII ALL TYPE**  
*VUE DE COTE / SIDE VIEW*

Designer

PS

Plan N° :  
DEL 0006

Date

23/05/2013

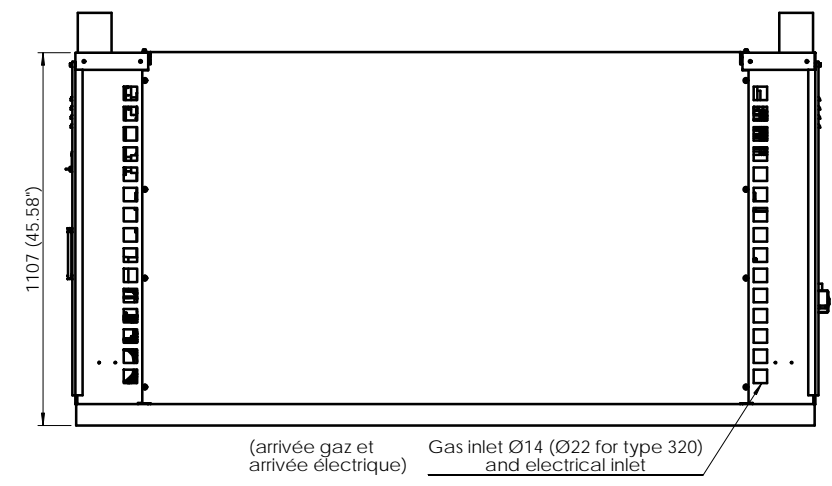
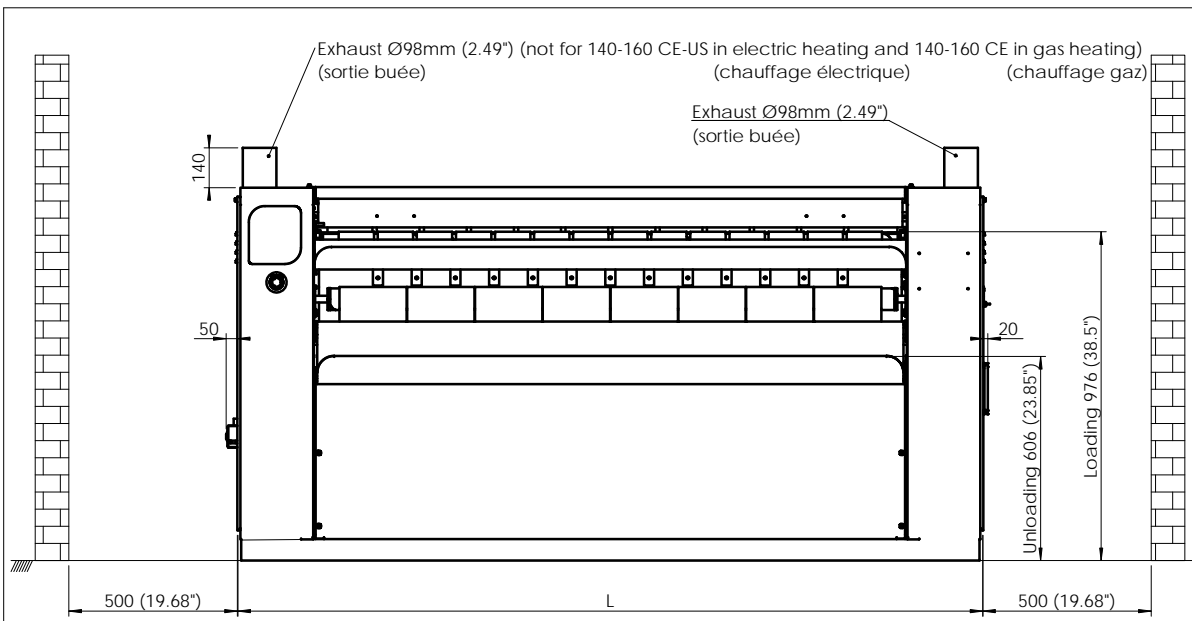

TYPE	140	160	200	320
L(mm/inch)	1960/77.16	2210/87	2560/100.79	3918/154.25
W(mm/inch)	644/25.35	644/25.35	644/25.35	860/33.86

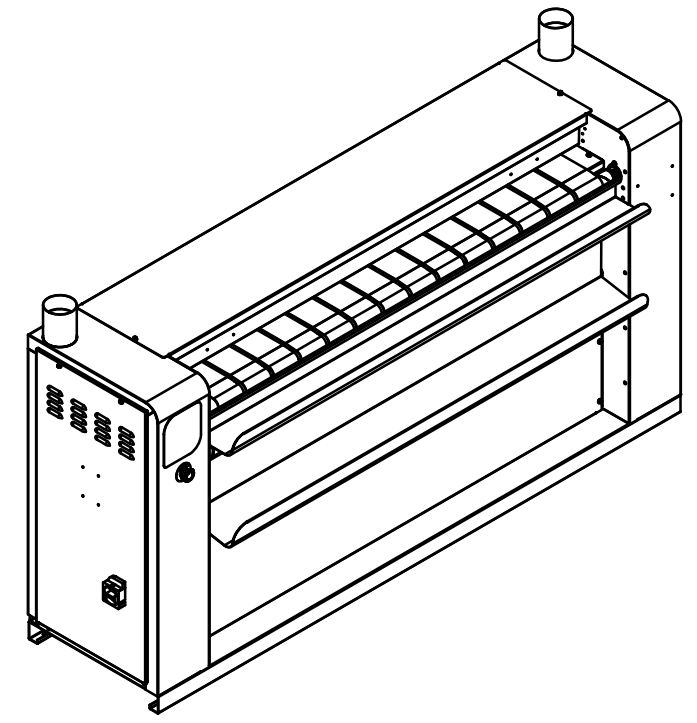
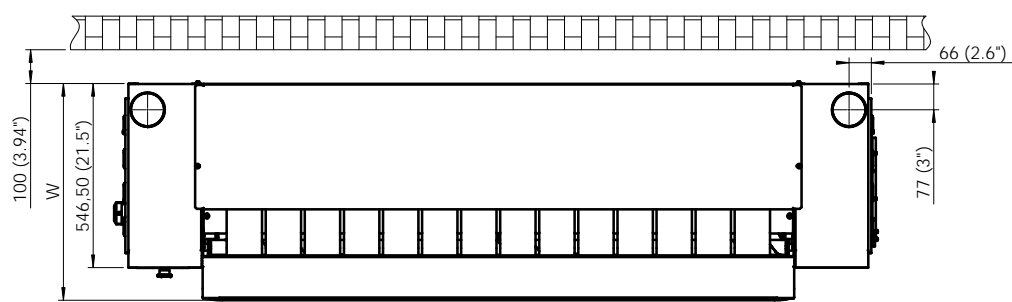

<b>Ø32-140/160/200/320 CE-US</b> PLAN D'IMPLANTATION/LAY OUT DRAWING	Designer	PS	Plan N° : DEL 0017-a
	Date	06/05/15	